

CARES Technical Approval Report TA7 5032



 **LinkStudPSR™**

LinkStudPSR
Punching Shear Reinforcement System

Assessment of the
LinkStudPSR Punching
Shear Reinforcement System

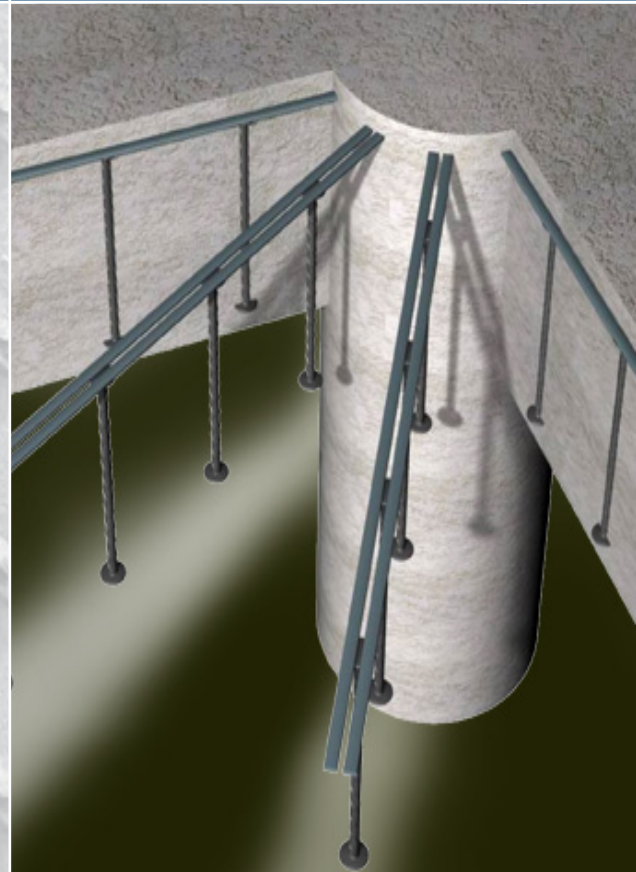

Electronic Copy www.ukcares.com

Product

LinkStudPSR Punching Shear Reinforcement System

Provided by:

LinkStudPSR Limited
Gloucester House
Anson Court
Dyson Way
Stafford ST18 0GB

Tel: +44 (0)8456 528 528

Fax: +44 (0)8456 528 528

1 Product Summary

The LinkStudPSR system comprises short lengths of carbon steel ribbed bar reinforcement with end anchorages provided by enlarged, hot forged heads at both ends, giving a cross-sectional area ratio of 9:1. The stud heads are cast in the slab, and increase the resistance to punching shear.

The double-headed LinkStudPSR shear studs are welded to non-structural carrier / spacer rails to allow them to be located correctly in accordance with the design, and where appropriate to be supported by the top flexural reinforcement.

1.1 Scope of Application

The LinkStudPSR Punching Shear Reinforcement System has been evaluated for use in reinforced concrete slabs and footings, designed for shear in accordance with "BS EN 1992-1-1 1994 (Eurocode 2).

1.2 Design Considerations

Eurocode 2 (EC2) describes shear reinforcement in terms of traditional links or bent-up bars arranged along perimeters at calculated distances around a loaded area (e.g. column or pile); with these calculations being relative to the size and position of the loaded area in conjunction with the depth and construction of the adjoining slab.

Where proprietary products are to be used as shear reinforcement, EC2 requires that $V_{Rd,cs}$ (the design value of punching shear resistance of a slab with shear reinforcement calculated for the control perimeter u_1) should be determined by testing in accordance with the relevant European Technical Approval.

The present approval relates to shear reinforcement designed according to Eurocode 2. It does not cover designs made to BS8110 which has been withdrawn.

This need not present a problem in cases where a structure, including the flexural reinforcement of its floor slabs, has been designed to BS8110. The shear reinforcement can be safely designed and detailed to EC2.



In the view of CARES, the basis of design and detailing, adopted for a shear reinforcement system other than links or bent-up bars, should be similar to that of the design standard, with amendments made only to take account of particular features of the system in question.

The performance of the system should be experimentally validated against a design method, and the test results should show that the system functions essentially as designed and gives resistances at least equal to the calculated characteristic resistances.

Deviations from the design standard in relation to detailing requirements and / or other limits require additional structural testing.

The design standard contains various detailing requirements, particularly in relation to the spacing of the elements of shear reinforcement and various limits on, for example, the concrete compressive strength which may be taken into account when designing against punching.

1.3 Conclusion

It is the opinion of UK CARES that the LinkStudPSR Punching Shear Reinforcement System is satisfactory for use within the limits stated in paragraph 1.1.

B. Bowsher
Executive Director, August 2010



2 Technical Specification

2.1 General



**Figure 1 -
LinkStudPSR Punching
Shear Reinforcement**

The LinkStudPSR Punching Shear Reinforcement (PSR) system's shear studs are manufactured from lengths of Grade B500C ribbed carbon steel reinforcing bars with a characteristic yield strength of 500 N/mm². The bars are upset hot forged to provide a 'head' on each end of the bar of three times the diameter of the stud shaft. This provides effective anchorage of the stud within the concrete.

The carbon steel rebar used is selected to fully comply with the requirements of EC2, whilst being fully compatible with the outgoing BS 8110 standard. The use of a ribbed bar also provides the advantages of being easily and fully traceable back to the steel mill and conforming to BS4449:2005.

The LinkStudPSR system studs are available in shaft diameters from 10 mm to 25 mm and in a full range of lengths in 5 mm increments. All studs are factory welded to non-structural carrier / spacer rails at predetermined positions that have been calculated in accordance with the relevant design standard and the LinkStudPSR Design Manual; thus arranging the placement of the shear reinforcement.

3 Product Performance and Characteristics

3.1 Material Properties

The LinkStudPSR system shear studs are manufactured from Grade B500C ribbed carbon steel QST reinforcing bars with a characteristic yield strength of 500 N/mm², which fully complies with BS4449:2005. The carrier / spacer rails are cut from strips of mild steel S275JR, complying with BS EN 10025.

3.2 Production Processes

The LinkStudPSR system comprises a series of studs which are upset forged to provide a 'head' on each end of the bar of three times the diameter of the stud shaft, giving a cross sectional area of 9:1.

The forged studs retain the inherent strength of the ribbed carbon steel reinforcing bar, by maintaining the homogenous metal grain flow and being quenched and self tempered (QST), thus providing the finished shear reinforcement studs with a high strength outer layer combined with a more ductile core.

The finished studs are factory welded to the carrier rails at predetermined centres in accordance with the relevant EC2 or BS8110 design standard under a BS EN ISO 9001:2008 Quality Management System (QMS).

3.3 Design Method and Detailing Requirements

The LinkStudPSR Ltd design methodology closely follows the requirements of both the new BS EN 1992-1-1 (2004) (EC2) design standard.

The most common layouts would see an EC2 compliant design using a radial pattern layout (with a cruciform pattern being available as an option in certain circumstances), with checks being made at the face of the loaded area, at 2d (the basic control perimeter) and at the outermost limit beyond which shear reinforcement is no longer required.

To make the designing and detailing of Punching Shear Reinforcement to EC2 easier, LinkStudPSR Ltd provide a comprehensive design support service, however, it is ultimately the Project Engineer's responsibility to ensure the correct shear reinforcement is specified, designed and the relevant detailing requirements are met.



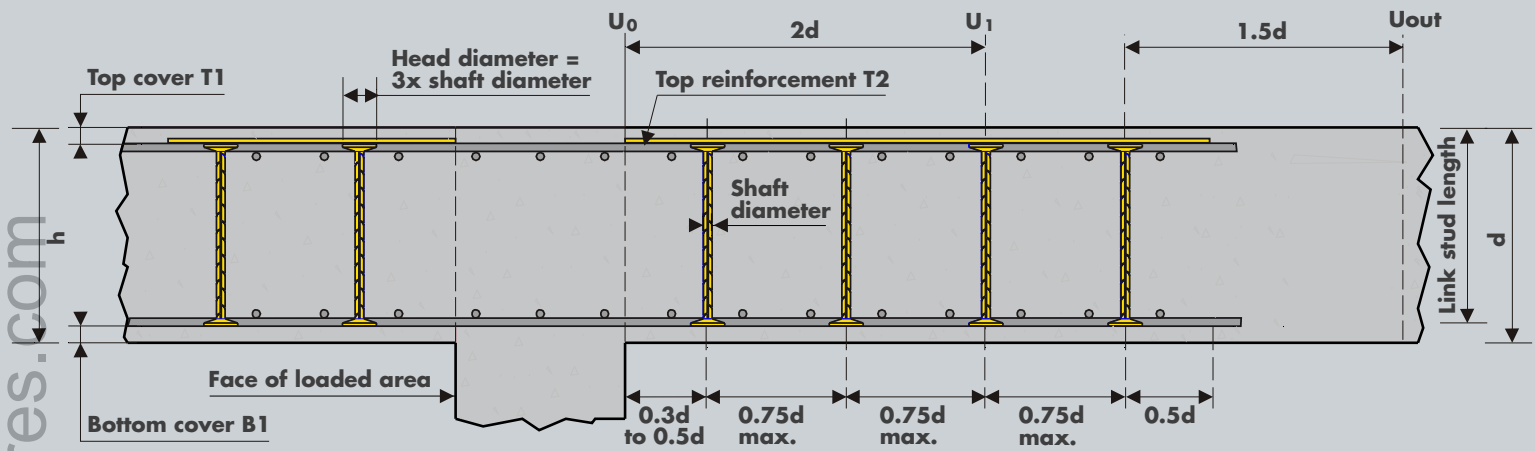

Figure 2 - Detailing requirements to EC2

The main* detailing requirements to EC2 are:

- 1) The distance from the face of the loaded area to the first stud should be 0.3d to 0.5d when using a radial pattern layout.
- 2) The spacing of subsequent studs along the rail should be no more than 0.75d.
- 3) When using a radial pattern layout the tangential spacing of studs within the basic control perimeter at 2d should be no more than 1.5d, and the tangential spacing outside of the basic control perimeter should be no more than 2d, where that part of the perimeter is assumed to contribute to the shear capacity.
- 4) When using a cruciform pattern the spacing of studs within the basic control perimeter should be no more than 1.5d. Refer to Eurocode 2 for detail information.
- 5) The outermost perimeter of shear reinforcement should be placed at a distance not greater than 1.5d within the outer perimeter beyond which shear reinforcement is no longer required.
- 6) The carrier / spacer rails are non structural and can be placed on the top of the top reinforcement (T1) or under the bottom reinforcement (B1).
- 7) When installed in the most commonly used 'studs down' style the top of the stud (where it is welded to the rail) should sit level with the uppermost surface of the (T1) top layer of reinforcement bars and the very bottom of the stud should sit level with the lowest part of the B1 bars, but allowing a tolerance of - 5 mm, which may arise from the studs being manufactured in 5 mm length increments and the need to avoid a reduction of the bottom cover. (The same principle applies when installing the LinkStudPSR system in the 'studs up' style.)

* For comprehensive information, please refer to Eurocode 2.

4 Installation

4.1 Placement of the Studs

Each carrier rail is labelled with the specific stud information and spacing specific to that rail in order that it can be easily identified by installers.

The studs must always 'capture' the main reinforcement within the slab – see section 3.3 for detailed information.

In most situations the LinkStudPSR system carrier / spacer rails are simply placed on top of the top (T1) main reinforcement bars after the main reinforcement and accessories have been installed, with the studs pointing downwards. The rails are then secured in position, usually with wire, to ensure that the studs remain in the correct position whilst the concrete is poured.

In situations where the carrier rails may run parallel to the T1 reinforcement, additional spacer bars can be quickly and easily welded or wire tied to the main T2 reinforcement to raise the level of the carrier rails to sit at the same height as if they were placed on the T1 bars. These spacer bars can be supplied as required.

If installing the studs using the 'studs up' style (before the main reinforcement is installed), then the rails should be laid out in accordance with the design, placed on concrete spacers to ensure the correct cover is provided and then nailed to the bottom formwork (between the twin rails) to ensure that the studs remain in the correct position whilst the concrete is poured. Care should also be taken when installing the main reinforcement so as to not displace the studs.



4.2 Storage

The LinkStudPSR rails are normally delivered to site stacked, steel banded and shrink wrapped securely on pallets. The studs are interlaced during transport to provide stability and to reduce the risk of damage before they are required.

Order schedules are attached to the pallets for ease of recognition and confirmation of rails delivered. It is suggested that this documentation is retained at a central point / site office as soon as possible after the delivery has arrived to allow for traceability and for site records.

It is recommended that the pallets are offloaded via forklift or crane (with appropriate slings or lifting system as required) and stored in the area of the site where they are likely to be used to ensure ease of access. Another reason for this practice is that once the steel bands are removed the load may shift or relax slightly on the pallet, making it difficult to move again as a safe load.

Although the LinkStudPSR system is made of carbon steel and is therefore robust in nature, it is suggested that the rails are stored in an area where they are less likely to encounter damage from site traffic.

Once the LinkStudPSR system is exposed to the elements it can be treated in the same manner as normal steel reinforcing bar. Over time, the studs and rails may show some signs of surface rust, but unless the exposure is over many months of inclement weather, this is very unlikely to affect the structural capabilities of the product.

5 Safety Considerations

Although made of steel and therefore collectively a very heavy material, each LinkStudPSR rail is relatively lightweight and should be easily handled by one site operative alone.

As with any construction site, appropriate safety and PPE should be worn to protect the user, such as thick protective gloves as worn when handling any reinforcing steel, safety footwear in case of dropping the rails and eye protection, especially if it is necessary to cut a rail to fit the reinforcement layout. Care should also be taken when removing the steel bands from the pallets as the release of tension could cause the steel band to whip onto the site staff or bystanders.

Care should be taken, especially on congested sites, when handling long rails or studs that they do not get caught up in equipment or materials in the immediate area.

6 Product Testing and Evaluation

Independent testing of the LinkStudPSR system for CARES has been primarily undertaken at the Cambridge University test facilities with further testing undertaken at other UK-based independent testing bodies.

A series of structural tests has been completed to evaluate shear performance to EC2 design standards in addition to the requirements of CARES Appendix TA7 'Quality and Operations Schedule for the Technical Approval of Stud Shear Reinforcing Systems for Flat Slabs'.

In accordance with the LinkStudPSR ISO 9001: 2008 Quality Management System, a sample from each batch of LinkStuds is also tested to destruction in the factory to ensure the continuity of the tensile strength of the steel and to provide additional confirmation of the compliance and suitability of the system to the design standards. Certificates of Conformity are available if required.

LinkStudPSR Limited utilises experts in structural engineering at the University of Sheffield as technical advisers and incorporates the guidance notes and recommendations of experts at The Concrete Society.

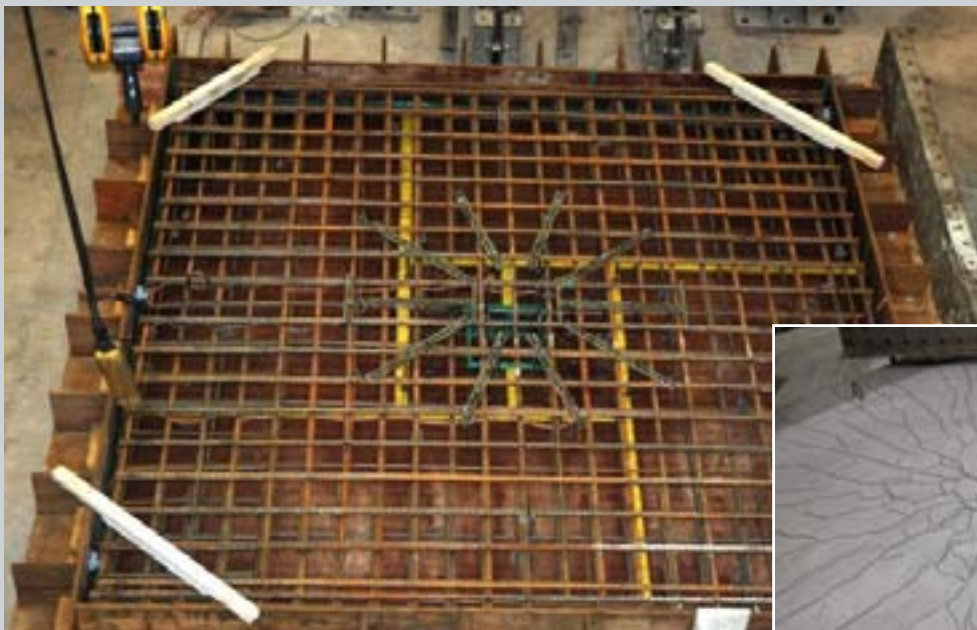

Figure 3 - LinkStudPSR Testing



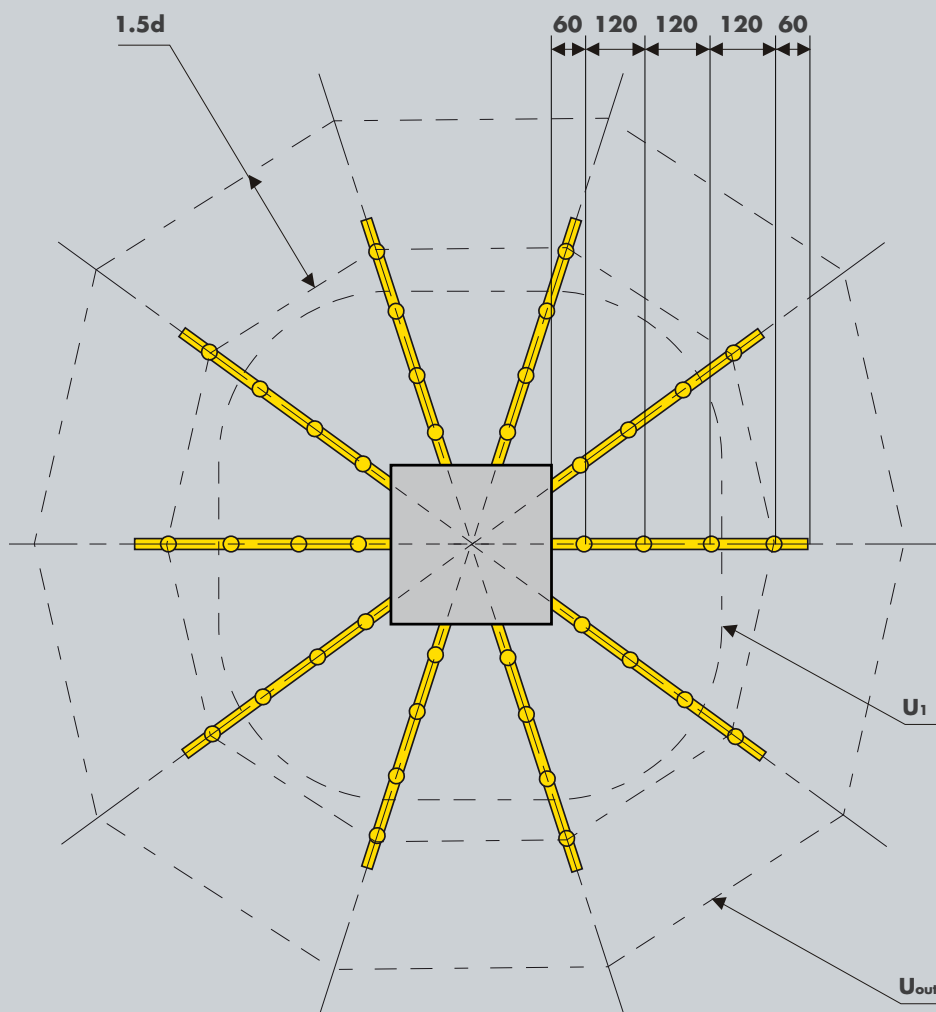

Figure 4 - LinkStudPSR Radial Configuration

7 Quality Assurance

It is the policy of LinkStudPSR Ltd to provide its customers with products which are fit for intended purpose and which conform to the appropriate national standards and the company's quality specification.

To provide the industry with independent proof of this, the LinkStudPSR system is made to order under the Company's ISO 9001: 2008 Quality Management System.

UK CARES: Quality Management System Certificate No. 5032

8 Building Regulations

Eurocodes

BS 8110 was withdrawn in April 2010 after its coexistence period with Eurocode 2 ended. Although not yet formally endorsed by the Secretary of State it is anticipated that under building regulations Eurocode 2 when used in conjunction with the national annex will be accepted in lieu of BS8110.

8.1 The Building Regulations (England and Wales)

Structure, Approved Document A

The LinkStudPSR Punching Shear Reinforcement (PSR) system, in CARES view, when used in Eurocode Code 2 designs in lieu of BS8110 designs and in accordance with this Technical Approval, will satisfy the relevant requirements of The Building Regulations (England and Wales), Approved Document A.

8.2 The Building Regulations (Northern Ireland)

Part D, Structure

The LinkStudPSR Punching Shear Reinforcement (PSR) system, in CARES view, when used in Eurocode Code 2 designs in lieu of BS8110 designs and in accordance with this Technical Approval, will satisfy the relevant requirements of The Building Regulations (Northern Ireland), Part D, Structure.

8.3 The Building (Scotland) Regulations

Non Domestic Technical Handbook

The LinkStudPSR Punching Shear Reinforcement (PSR) system, in CARES view, when used in Eurocode Code 2 designs in lieu of BS8110 designs and in accordance with this Technical Approval, will satisfy the relevant requirements of clause 1.1.3 Design and Construction.



9 References

- Eurocode 2: Design of concrete structures – Part 1-1: General rules and rules for buildings, BS EN 1992-1-1:2004
- NA to BS EN 1992-1-1:2004. UK National Annex to Eurocode 2: Design of concrete structures. General rules and rules for buildings.
- PD 6687:2006. Background paper to the UK National Annexes to BS EN 1992-1.
- CARES Appendix TA7 Quality and Operations Schedule for the Technical Approval of Stud Shear Reinforcing Systems for Flat Slabs.
- LinkStudPSR Design Manual to EC2 and BS8110, published by LinkStudPSR Ltd 2010
- BS 4449:2005: Steel for the reinforcement of concrete. Weldable reinforcing steel. Bar, coil and decoiled product. Specification.
- BS EN 10025-1:2004 Hot rolled products of structural steels. General technical delivery conditions.
- BS EN ISO 9001:2008 Quality Management Systems. Requirements.

10 Conditions

1. The quality of the materials and method of manufacture have been examined by CARES and found to be satisfactory. This Technical Approval will remain valid provided that:
 - a. The product design and specification are unchanged.
 - b) The materials and method of manufacture are unchanged.
 - c) The manufacturer complies with CARES regulations for Technical Approvals.
 - d) The manufacturer holds a valid CARES Certificate of Product Assessment.
 - e) The product is installed and used as described in this report.
2. CARES make no representation as to the presence or absence of patent rights subsisting in the product and / or the legal right of LinkStudPSR Ltd to market the product.
3. Any references to standards, codes or legislation are those which are in force at the date of this certificate.
4. Any recommendations relating to the safe use of this product are the minimum standards required when the product is used. These requirements do not purport to satisfy the requirements of the Health and Safety at Work etc Act 1974 or any other relevant safety legislation.
5. CARES does not accept any responsibility for any loss or injury arising as a direct or indirect result of the use of this product.
6. This Technical Approval Report should be read in conjunction with CARES Certificate of Product Assessment No. 5032. Confirmation that this Technical Approval is current can be obtained from UK CARES.





Electronic Copy www.ukcares.com



UK CARES

Pembroke House
21 Pembroke Road
Sevenoaks
Kent TN13 1XR

Phone: +44(0)1732 450000
Fax: +44(0)1732 455917
E-mail: general@ukcares.com
URL: www.ukcares.com

**Independent Product Assessments
for the Construction Industry**

Copyright UK CARES ©